

## LM136-2.5/LM236-2.5/LM336-2.5V Reference Diode

### General Description

The LM136-2.5/LM236-2.5 and LM336-2.5 integrated circuits are precision 2.5V shunt regulator diodes. These monolithic IC voltage references operate as a low-temperature-coefficient 2.5V zener with 0.2Ω dynamic impedance. A third terminal on the LM136-2.5 allows the reference voltage and temperature coefficient to be trimmed easily.

The LM136-2.5 series is useful as a precision 2.5V low voltage reference for digital voltmeters, power supplies or op amp circuitry. The 2.5V make it convenient to obtain a stable reference from 5V logic supplies. Further, since the LM136-2.5 operates as a shunt regulator, it can be used as either a positive or negative voltage reference.

The LM136-2.5 is rated for operation over  $-55^{\circ}\text{C}$  to  $+125^{\circ}\text{C}$  while the LM236-2.5 is rated over a  $-25^{\circ}\text{C}$  to  $+85^{\circ}\text{C}$  temperature range.

The LM336-2.5 is rated for operation over a  $0^{\circ}\text{C}$  to  $+70^{\circ}\text{C}$  temperature range. See the connection diagrams for available packages.

### Features

- Low temperature coefficient
- Wide operating current of 400  $\mu\text{A}$  to 10 mA
- 0.2Ω dynamic impedance
- $\pm 1\%$  initial tolerance available
- Guaranteed temperature stability
- Easily trimmed for minimum temperature drift
- Fast turn-on

### Connection Diagrams

TO-92  
Plastic Package

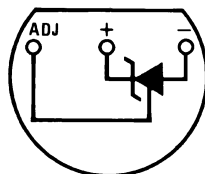

00571508

Bottom View

Order Number LM336Z-2.5 or LM336BZ-2.5  
See NS Package Number Z03A

TO-46  
Metal Can Package

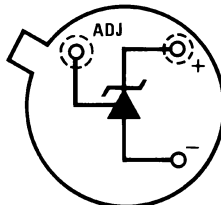

00571520

Bottom View

Order Number LM136H-2.5,  
LM136H-2.5/883, LM236H-2.5,  
or LM236AH-2.5  
See NS Package Number H03H

SO Package

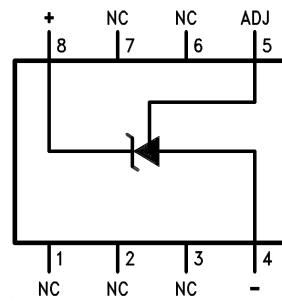

00571512

Top View

Order Number LM236M-2.5,  
LM236AM-2.5, LM336M-2.5  
or LM336BM-2.5  
See NS Package Number M08A

## Typical Applications

2.5V Reference

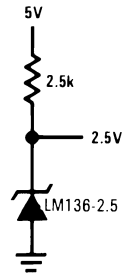

00571509

Wide Input Range Reference

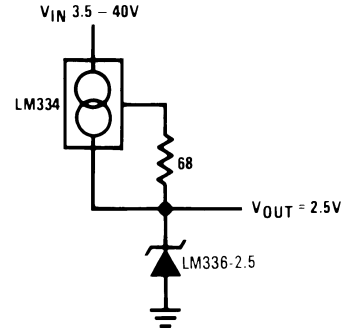

00571511

2.5V Reference with Minimum Temperature Coefficient

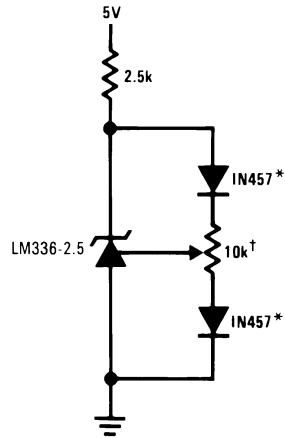

00571510

† Adjust to 2.490V

\* Any silicon signal diode

**Absolute Maximum Ratings** (Note 1)

If Military/Aerospace specified devices are required, please contact the National Semiconductor Sales Office/Distributors for availability and specifications.

Reverse Current	15 mA
Forward Current	10 mA
Storage Temperature	-60°C to +150°C
Operating Temperature Range (Note 2)	
LM136	-55°C to +150°C
LM236	-25°C to +85°C

LM336 0°C to +70°C

## Soldering Information

TO-92 Package (10 sec.)	260°C
TO-46 Package (10 sec.)	300°C
SO Package	
Vapor Phase (60 sec.)	215°C
Infrared (15 sec.)	220°C

See AN-450 "Surface Mounting Methods and Their Effect on Product Reliability" (Appendix D) for other methods of soldering surface mount devices.

**Electrical Characteristics** (Note 3)

Parameter	Conditions	LM136A-2.5/LM236A-2.5 LM136-2.5/LM236-2.5			LM336B-2.5 LM336-2.5			Units
		Min	Typ	Max	Min	Typ	Max	
		Reverse Breakdown Voltage	$T_A=25^\circ\text{C}$ , $I_R=1\text{ mA}$ LM136, LM236, LM336 LM136A, LM236A, LM336B	2.440	2.490	2.540	2.390	
Reverse Breakdown Change With Current	$T_A=25^\circ\text{C}$ , $400\ \mu\text{A} \leq I_R \leq 10\text{ mA}$		2.6	6		2.6	10	mV
Reverse Dynamic Impedance	$T_A=25^\circ\text{C}$ , $I_R=1\text{ mA}$ , $f = 100\text{ Hz}$		0.2	0.6		0.2	1	$\Omega$
Temperature Stability (Note 4)	$V_R$ Adjusted to 2.490V $I_R=1\text{ mA}$ , Figure 2 $0^\circ\text{C} \leq T_A \leq 70^\circ\text{C}$ (LM336) $-25^\circ\text{C} \leq T_A \leq +85^\circ\text{C}$ (LM236H, LM236Z) $-25^\circ\text{C} \leq T_A \leq +85^\circ\text{C}$ (LM236M) $-55^\circ\text{C} \leq T_A \leq +125^\circ\text{C}$ (LM136)					1.8	6	mV mV mV mV
Reverse Breakdown Change With Current	$400\ \mu\text{A} \leq I_R \leq 10\text{ mA}$		3	10		3	12	mV
Reverse Dynamic Impedance	$I_R=1\text{ mA}$		0.4	1		0.4	1.4	$\Omega$
Long Term Stability	$T_A=25^\circ\text{C} \pm 0.1^\circ\text{C}$ , $I_R=1\text{ mA}$ , $t = 1000\text{ hrs}$		20			20		ppm

**Note 1:** Absolute Maximum Ratings indicate limits beyond which damage to the device may occur. Electrical specifications do not apply when operating the device beyond its specified operating conditions.

**Note 2:** For elevated temperature operation,  $T_j$  max is:

LM136	150°C
LM236	125°C
LM336	100°C

Thermal Resistance	TO-92	TO-46	SO-8
$\theta_{ja}$ (Junction to Ambient)	180°C/W (0.4" leads) 170°C/W (0.125" lead)	440°C/W	165°C/W
$\theta_{ja}$ (Junction to Case)	n/a	80°C/W	n/a

## Electrical Characteristics (Note 3) (Continued)

**Note 3:** Unless otherwise specified, the LM136-2.5 is specified from  $-55^{\circ}\text{C} \leq T_A \leq +125^{\circ}\text{C}$ , the LM236-2.5 from  $-25^{\circ}\text{C} \leq T_A \leq +85^{\circ}\text{C}$  and the LM336-2.5 from  $0^{\circ}\text{C} \leq T_A \leq +70^{\circ}\text{C}$ .

**Note 4:** Temperature stability for the LM336 and LM236 family is guaranteed by design. Design limits are guaranteed (but not 100% production tested) over the indicated temperature and supply voltage ranges. These limits are not used to calculate outgoing quality levels. Stability is defined as the maximum change in  $V_{\text{ref}}$  from  $25^{\circ}\text{C}$  to  $T_A$  (min) or  $T_A$  (max).

# Typical Performance Characteristics

Reverse Voltage Change

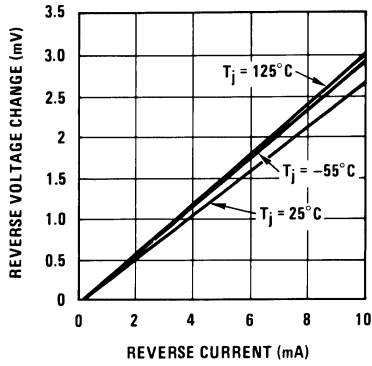

00571521

Zener Noise Voltage

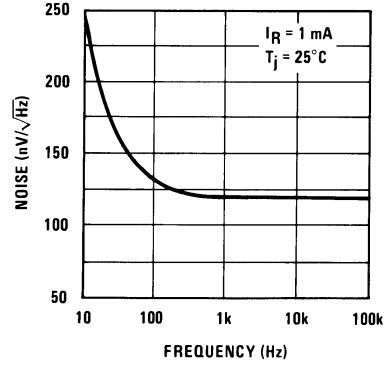

00571522

Dynamic Impedance

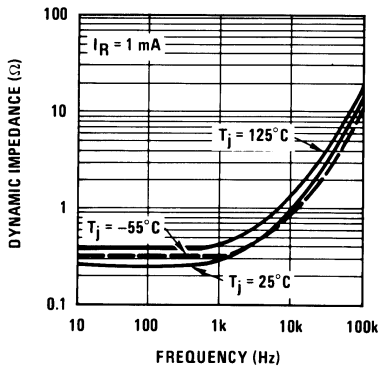

00571523

Response Time

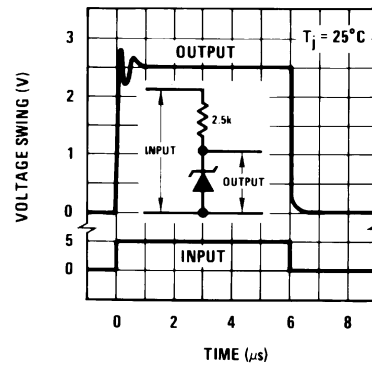

00571524

Reverse Characteristics

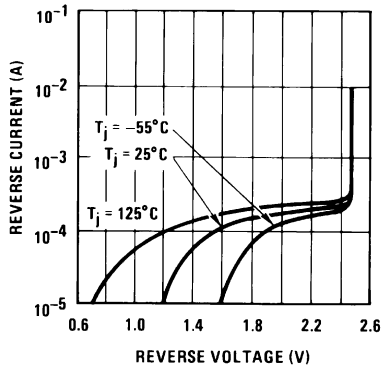

00571525

Forward Characteristics

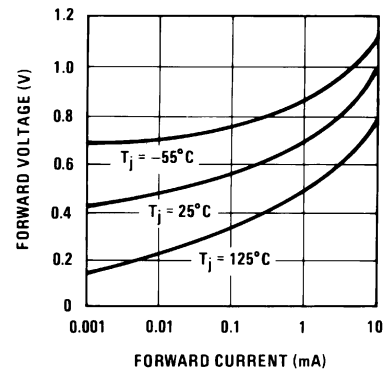

00571526

## Typical Performance Characteristics (Continued)

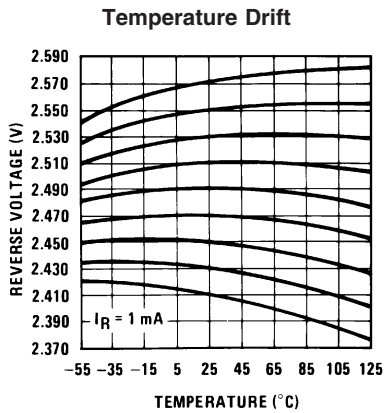

00571527

### Application Hints

The LM136 series voltage references are much easier to use than ordinary zener diodes. Their low impedance and wide operating current range simplify biasing in almost any circuit. Further, either the breakdown voltage or the temperature coefficient can be adjusted to optimize circuit performance.

Figure 1 shows an LM136 with a 10k potentiometer for adjusting the reverse breakdown voltage. With the addition of R1 the breakdown voltage can be adjusted without affecting the temperature coefficient of the device. The adjustment range is usually sufficient to adjust for both the initial device tolerance and inaccuracies in buffer circuitry.

If minimum temperature coefficient is desired, two diodes can be added in series with the adjustment potentiometer as shown in Figure 2. When the device is adjusted to 2.490V the temperature coefficient is minimized. Almost any silicon signal diode can be used for this purpose such as a 1N914, 1N4148 or a 1N457. For proper temperature compensation the diodes should be in the same thermal environment as the LM136. It is usually sufficient to mount the diodes near the LM136 on the printed circuit board. The absolute resistance of R1 is not critical and any value from 2k to 20k will work.

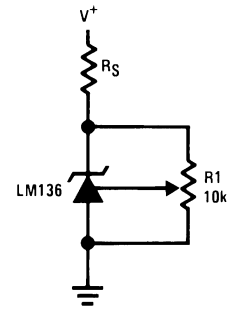

00571528

FIGURE 1. LM136 With Pot for Adjustment of Breakdown Voltage (Trim Range = ±120 mV typical)

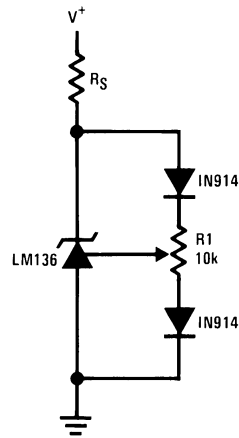

00571529

FIGURE 2. Temperature Coefficient Adjustment (Trim Range = ±70 mV typical)

Application Hints (Continued)

Low Cost 2 Amp Switching Regulator†

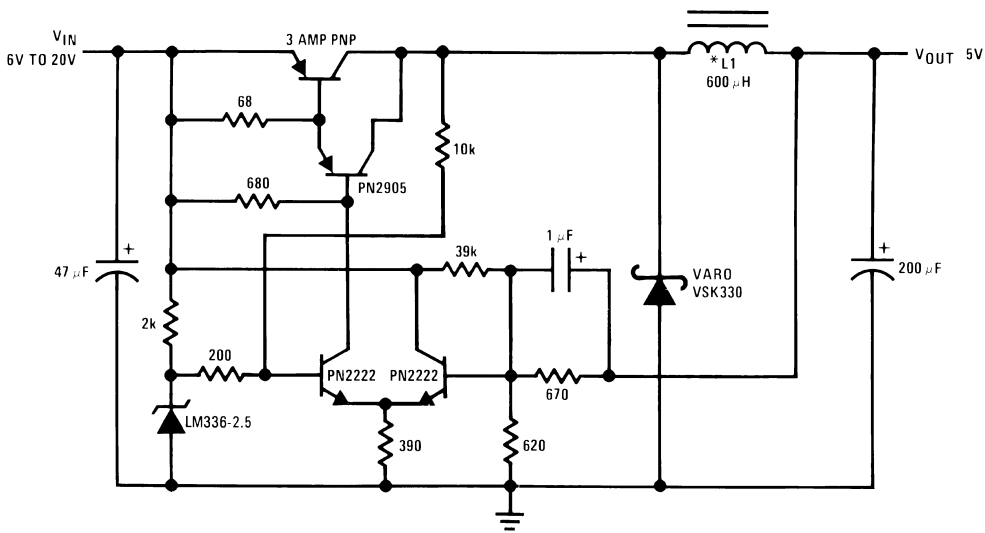

00571505

\*L1 60 turns #16 wire on Arnold Core A-254168-2

†Efficiency ≈ 80%

Precision Power Regulator with Low Temperature Coefficient

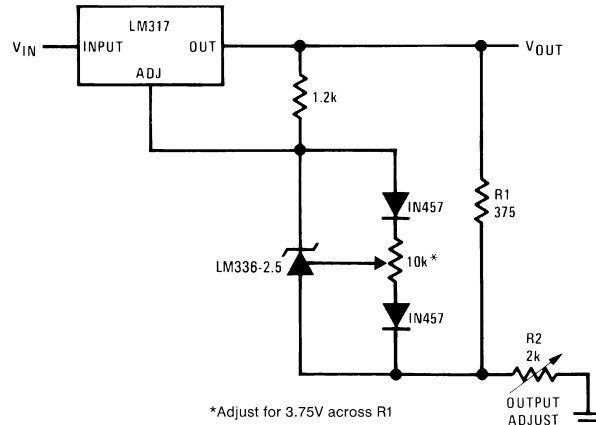

00571513

5V Crowbar

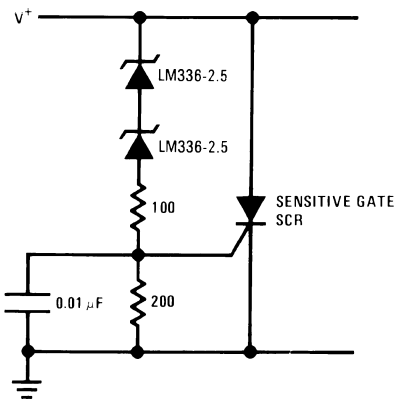

00571514

Trimmed 2.5V Reference with Temperature Coefficient Independent of Breakdown Voltage

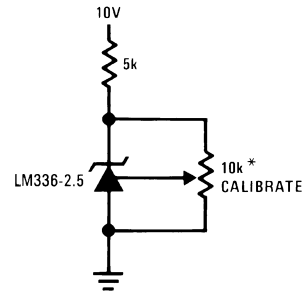

\*Does not affect temperature coefficient

00571515

# Application Hints (Continued)

## Adjustable Shunt Regulator

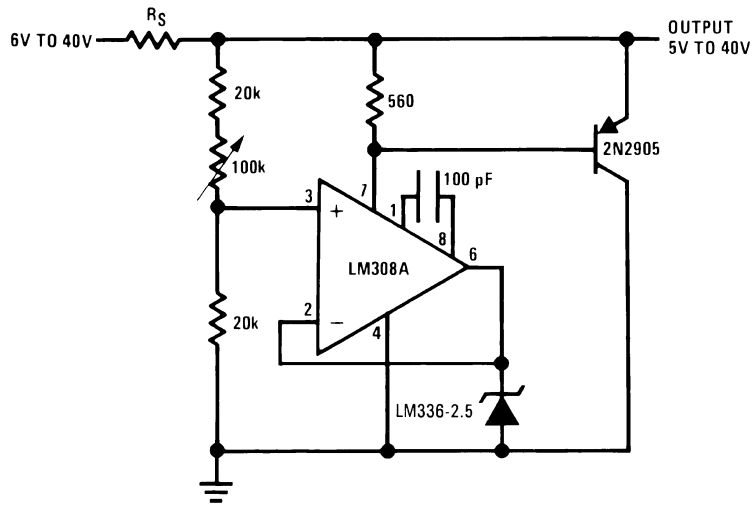

00571506

## Linear Ohmmeter

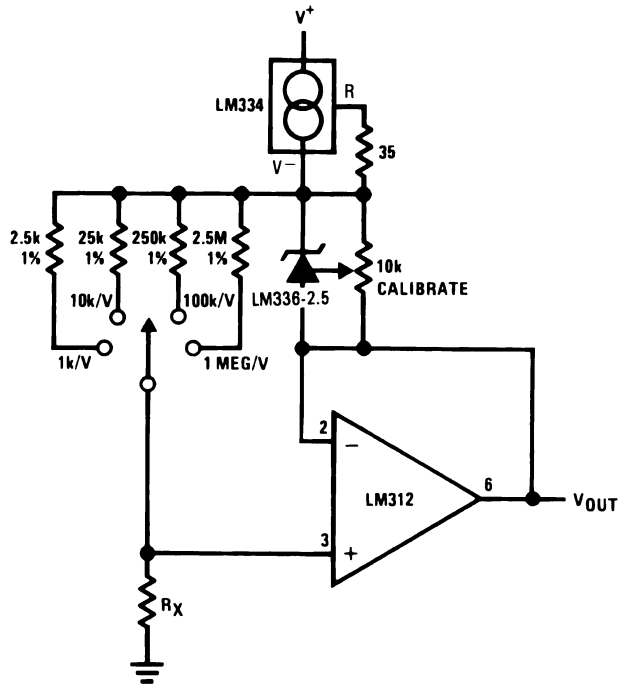

00571516

# Application Hints (Continued)

Op Amp with Output Clamped

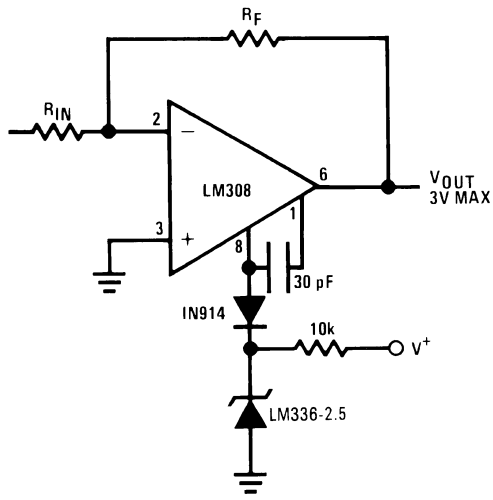

00571517

2.5V Square Wave Calibrator

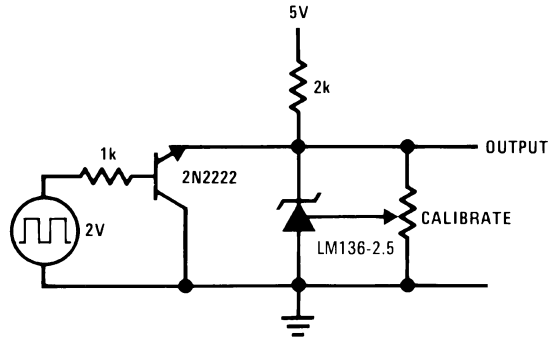

00571519

Bipolar Output Reference

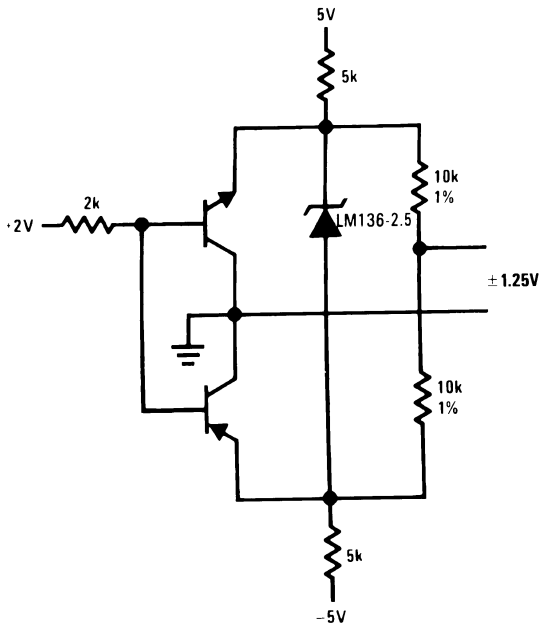

00571518

5V Buffered Reference

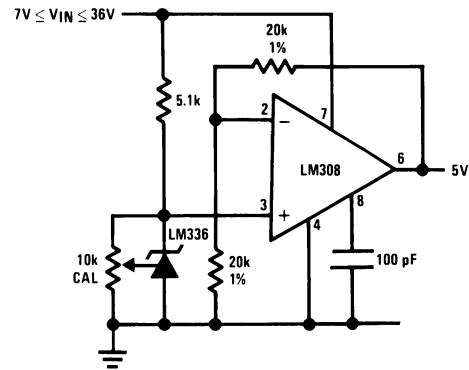

00571530

Low Noise Buffered Reference

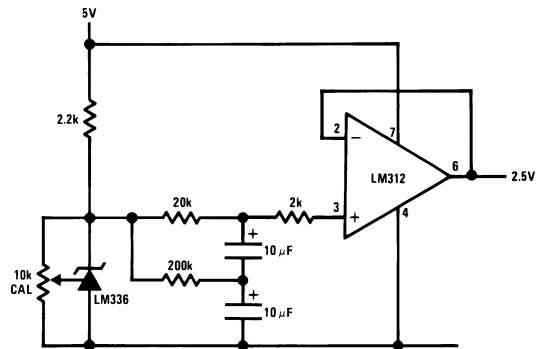

00571531

### Schematic Diagram

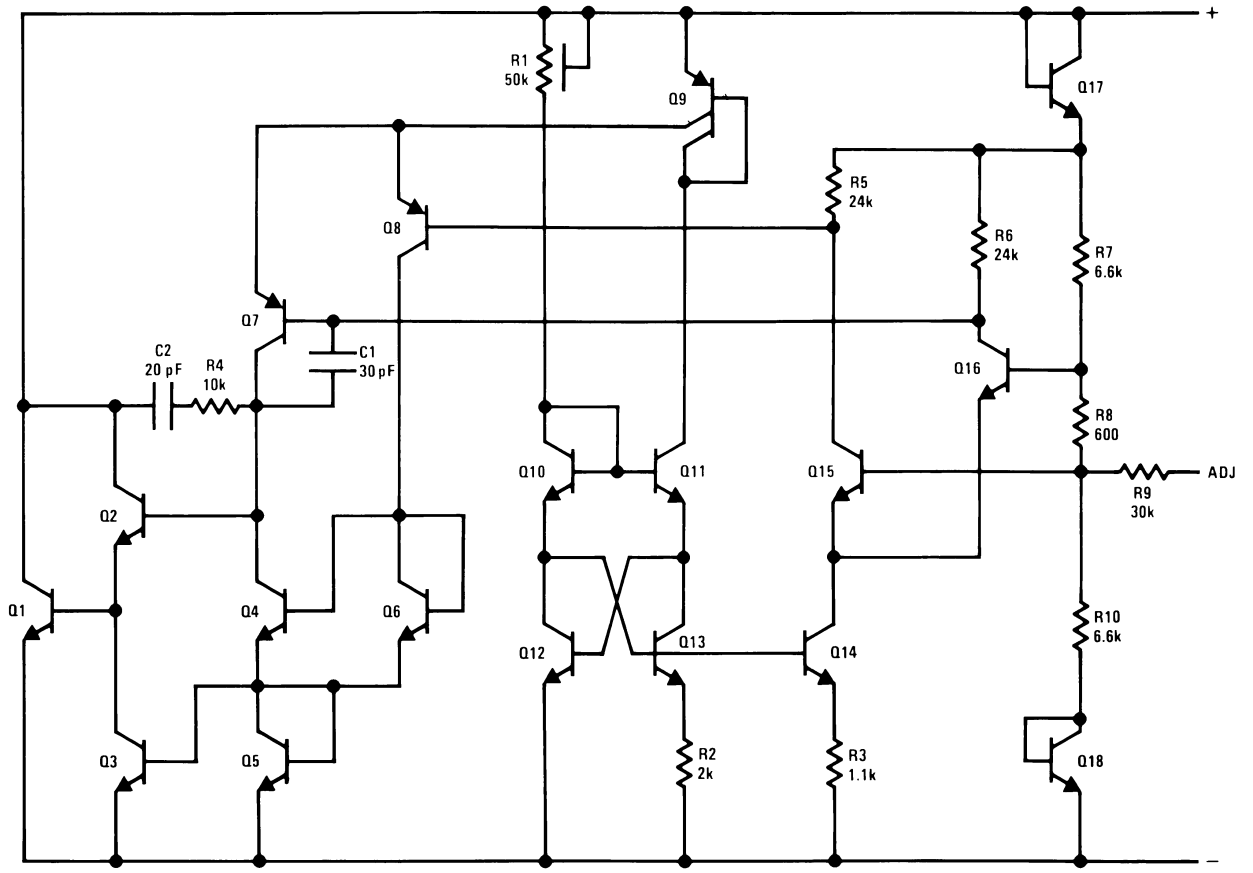

00571501



**Physical Dimensions** inches (millimeters) unless otherwise noted (Continued)

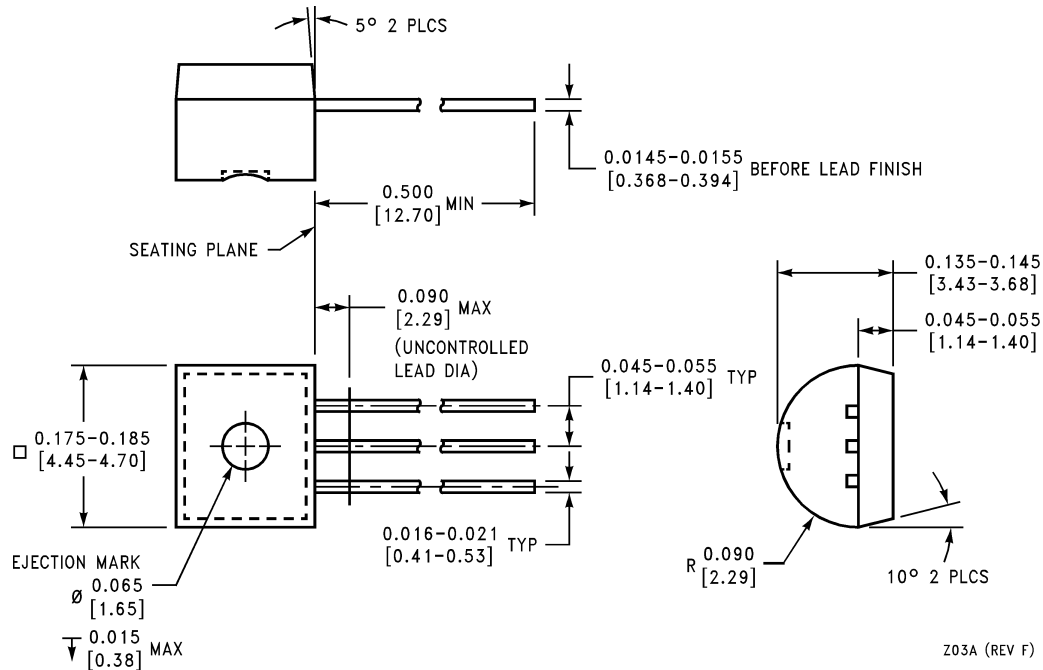

**TO-92 Plastic Package (Z)**  
**Order Number LM336Z-2.5 or LM336BZ-2.5**  
**NS Package Number Z03A**

National does not assume any responsibility for use of any circuitry described, no circuit patent licenses are implied and National reserves the right at any time without notice to change said circuitry and specifications.

For the most current product information visit us at [www.national.com](http://www.national.com).

**LIFE SUPPORT POLICY**

NATIONAL'S PRODUCTS ARE NOT AUTHORIZED FOR USE AS CRITICAL COMPONENTS IN LIFE SUPPORT DEVICES OR SYSTEMS WITHOUT THE EXPRESS WRITTEN APPROVAL OF THE PRESIDENT AND GENERAL COUNSEL OF NATIONAL SEMICONDUCTOR CORPORATION. As used herein:

1. Life support devices or systems are devices or systems which, (a) are intended for surgical implant into the body, or (b) support or sustain life, and whose failure to perform when properly used in accordance with instructions for use provided in the labeling, can be reasonably expected to result in a significant injury to the user.
2. A critical component is any component of a life support device or system whose failure to perform can be reasonably expected to cause the failure of the life support device or system, or to affect its safety or effectiveness.

**BANNED SUBSTANCE COMPLIANCE**

National Semiconductor certifies that the products and packing materials meet the provisions of the Customer Products Stewardship Specification (CSP-9-111C2) and the Banned Substances and Materials of Interest Specification (CSP-9-111S2) and contain no "Banned Substances" as defined in CSP-9-111S2.

 **National Semiconductor**  
**Americas Customer Support Center**  
 Email: [new.feedback@nsc.com](mailto:new.feedback@nsc.com)  
 Tel: 1-800-272-9959

**National Semiconductor**  
**Europe Customer Support Center**  
 Fax: +49 (0) 180-530 85 86  
 Email: [europe.support@nsc.com](mailto:europe.support@nsc.com)  
 Deutsch Tel: +49 (0) 69 9508 6208  
 English Tel: +44 (0) 870 24 0 2171  
 Français Tel: +33 (0) 1 41 91 8790

**National Semiconductor**  
**Asia Pacific Customer Support Center**  
 Email: [ap.support@nsc.com](mailto:ap.support@nsc.com)

**National Semiconductor**  
**Japan Customer Support Center**  
 Fax: 81-3-5639-7507  
 Email: [jpn.feedback@nsc.com](mailto:jpn.feedback@nsc.com)  
 Tel: 81-3-5639-7560